

DETAIL SHEETS

SITE PLAN

Details that should be shown on a site plan:

1. The site plan shall show the location of property lines, all buildings, all wells within 200 feet, septic tank, leachfield, water lines, streams and surface water bodies.
2. The septic tanks shall have the following minimum separation distances:
 - a. 5 ft from any dwelling
 - b. 10 ft from adjoining property lines
 - c. 25 ft from potable water lines
 - d. 50 ft from any water well
 - e. 50 ft from any waterways

Every site plan should have a North arrow

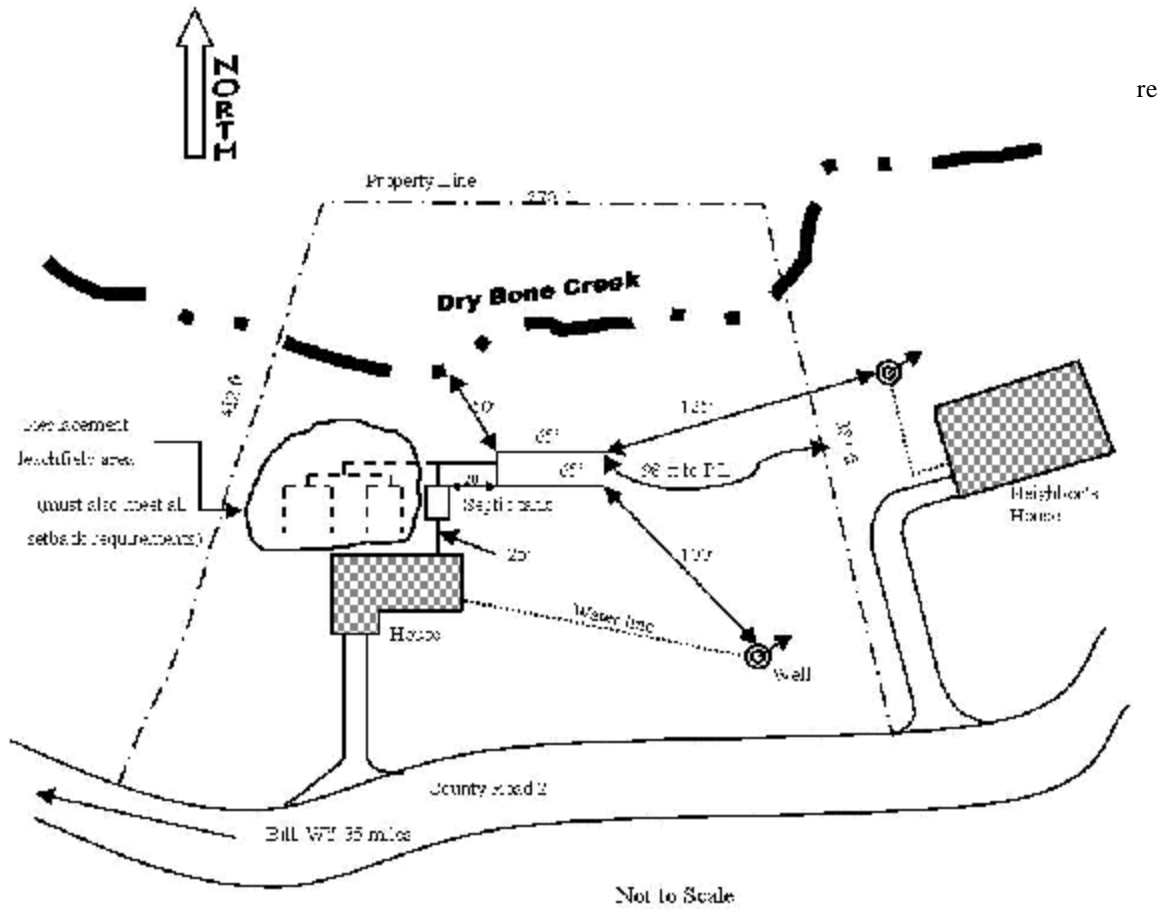

EXAMPLE

SITE PLAN

Standard Septic Tank

Manufacturer: _____ Model: _____

Rated Size: _____ gallons One Compartment _____, or Two Compartments _____

Is this septic tank on the Wyoming DEQ Approved Septic Tank List? if YES _____ ---- **STOP HERE!**
 if NO _____ ---- **CONTINUE!**

The requirements listed below and shown on the illustration apply to any tank used or site-built.

7. All small wastewater systems using a septic tank must have a minimum operating capacity of 1000 gallons. Additional capacity of 250 gallons per bedroom is required for each bedroom past four. Either one or two tanks may be used to meet this requirement.
8. The septic tank must be constructed of durable material not subject to rapid corrosion or decay and must be structurally sound and watertight. Steel tanks are not allowed.
9. Single compartment tanks shall have a minimum length to width ratio of 2:1.
10. Two compartment tanks shall have at least 50% of the volume in the first compartment.
11. Each compartment of the tank shall have an access opening with a minimum dimension of 20 inches in the least direction. Both inlet and outlet devices shall be accessible.
12. Clean-outs extending from each compartment to the surface with a minimum diameter of 6 inches must be provided. The access openings may be extended to the ground surface by use of a manway in lieu of a clean-out riser. All openings must be capped.

Material: _____ (such as concrete, polyethylene, etc.)

Inside dimensions in *Inches*

Length _____ Width _____ Height _____ Liquid Depth _____ Air Space _____

Operating Capacity = (Length * Width * Liquid Depth) / 231 = _____ gallons

Please complete the cross-section drawing below:

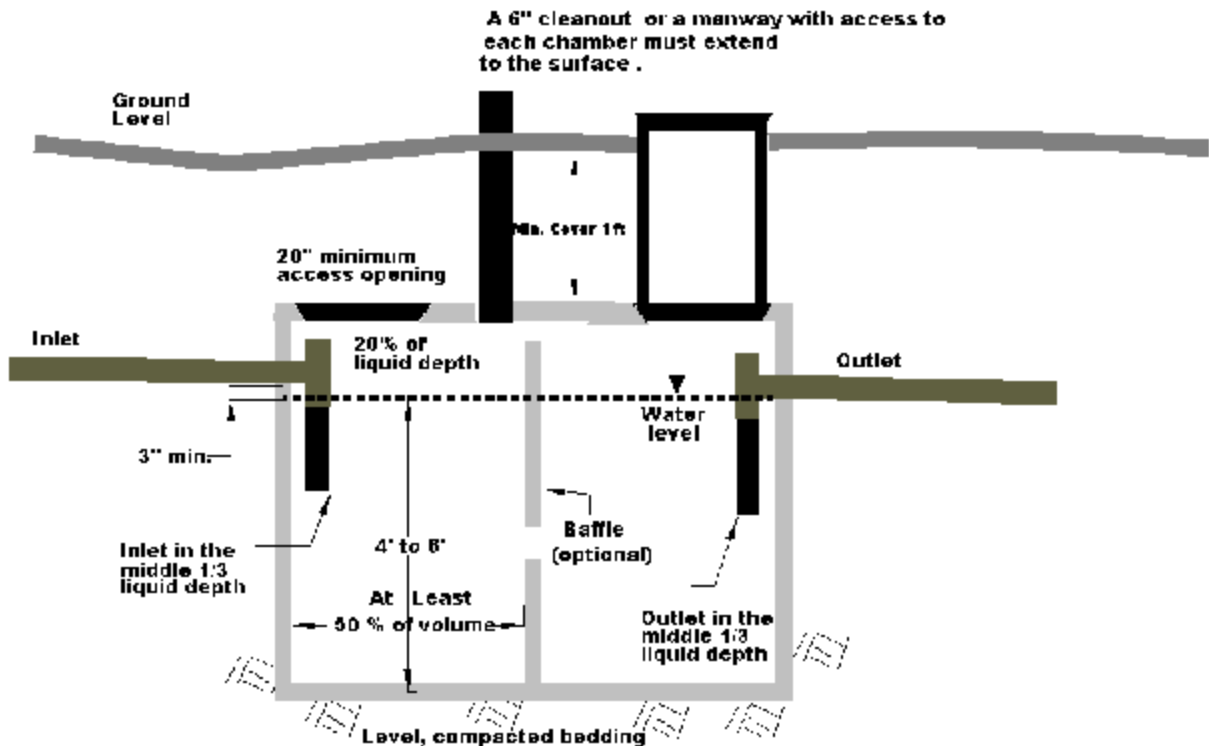

Single Trench Pipe Leachfield:

General Notes:

This form is for a standard trench leachfield using perforated pipe and washed rock or gravel.

Please supply the dimensions of your small wastewater system.

Every place there is a box, please fill in the dimensions of your system.

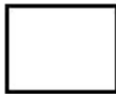

CROSS SECTION

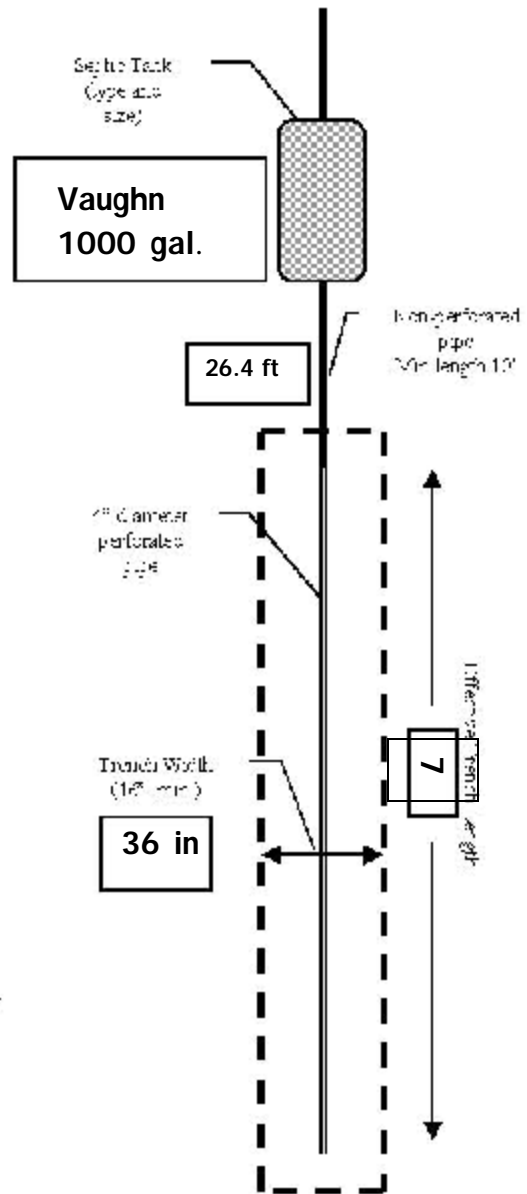
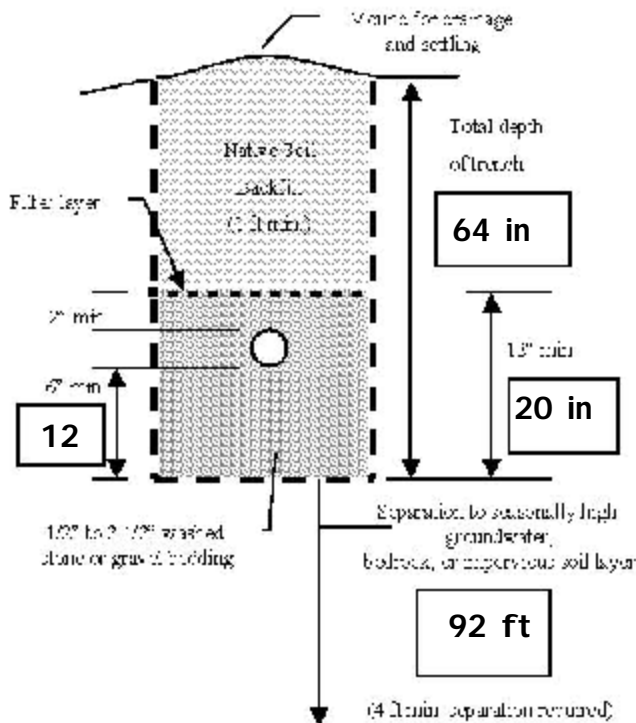

EXAMPLE

Single Trench Pipe Leachfield:

General Notes:

This form is for a standard trench leachfield using perforated pipe and washed rock or gravel.

Please supply the dimensions of your small wastewater system.

Every place there is a box, please fill in the dimensions of your system.

CROSS SECTION

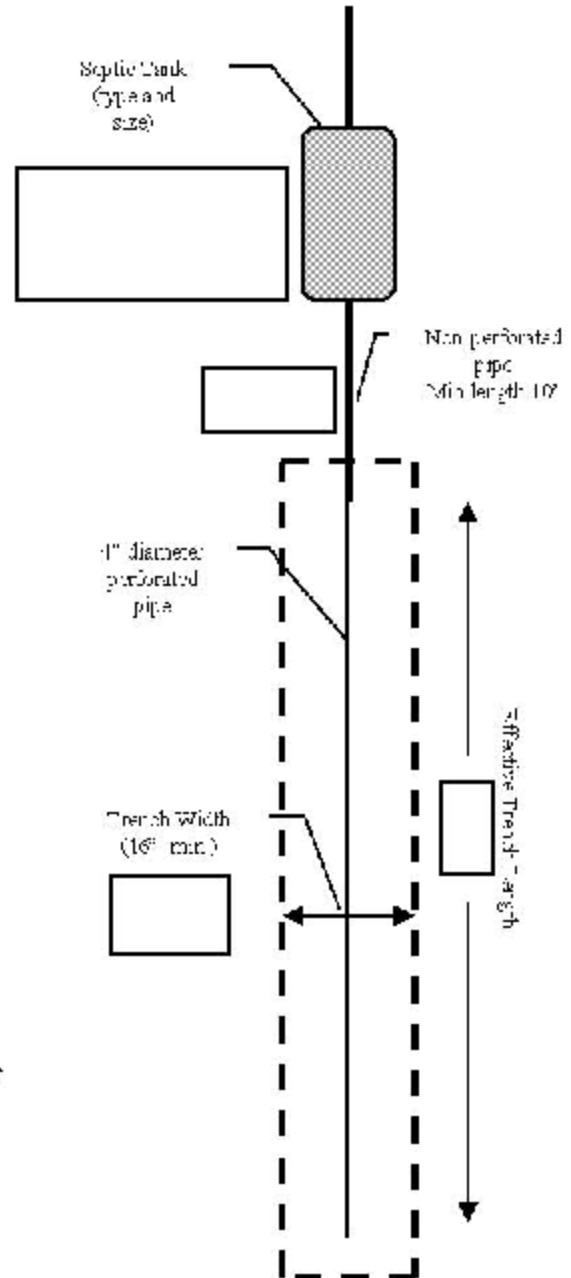
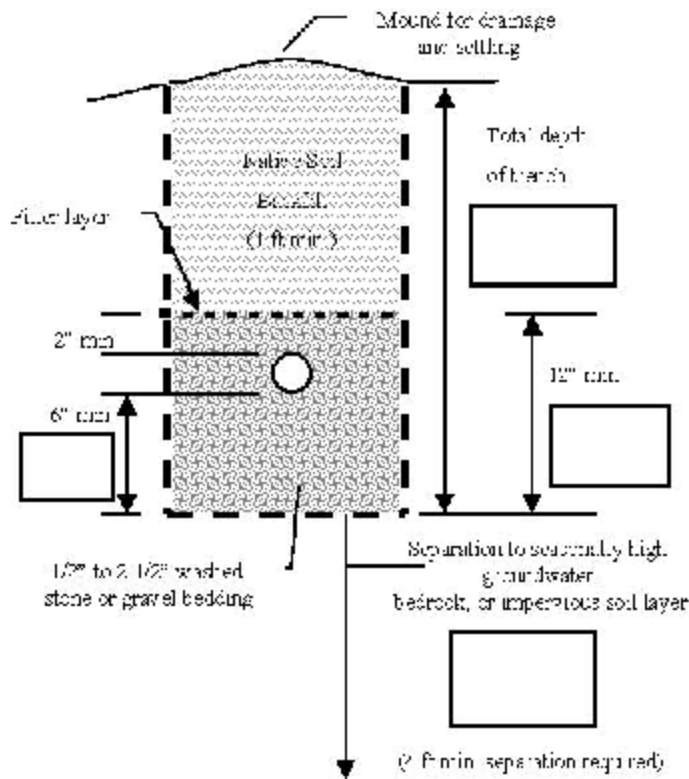

Two Trench Pipe Leachfield

General Notes:

This form is for a standard trench leachfield using perforated pipe and washed rock or gravel. Please supply the dimensions of your small wastewater system.

Every place there is a box, please fill in the dimensions of your system.



CROSS SECTION

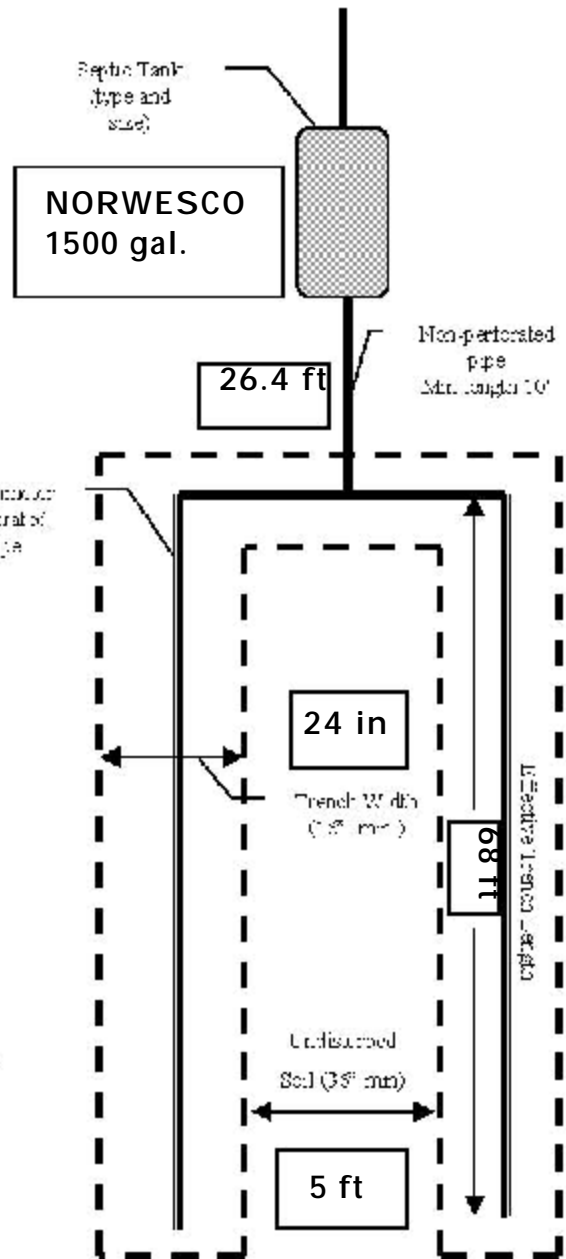
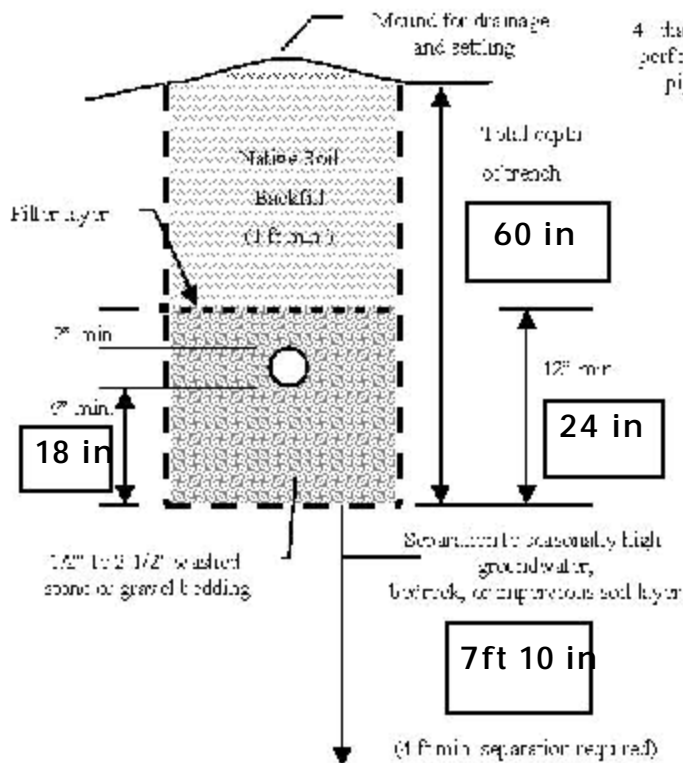

EXAMPLE

Two Trench Pipe Leachfield

General Notes:

This form is for a standard trench leachfield using perforated pipe and washed rock or gravel.

Please supply the dimensions of your small wastewater system.

Every place there is a box, please fill in the dimensions of your system.

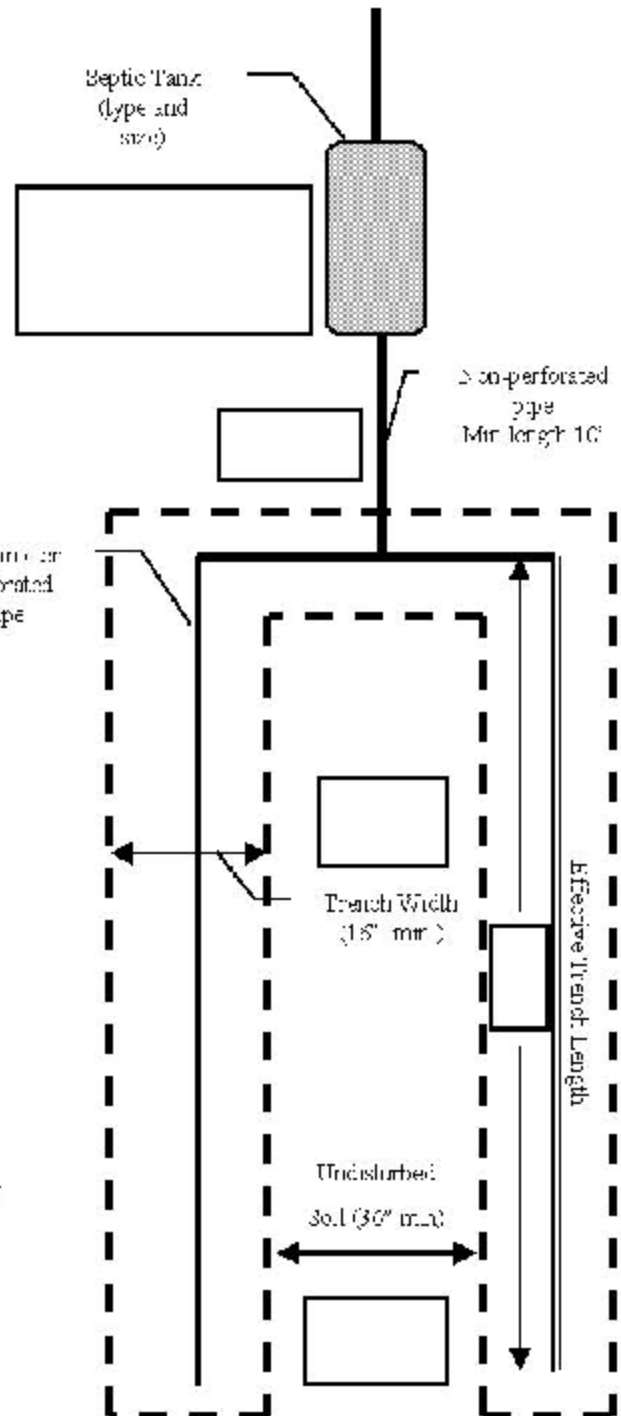

CROSS SECTION

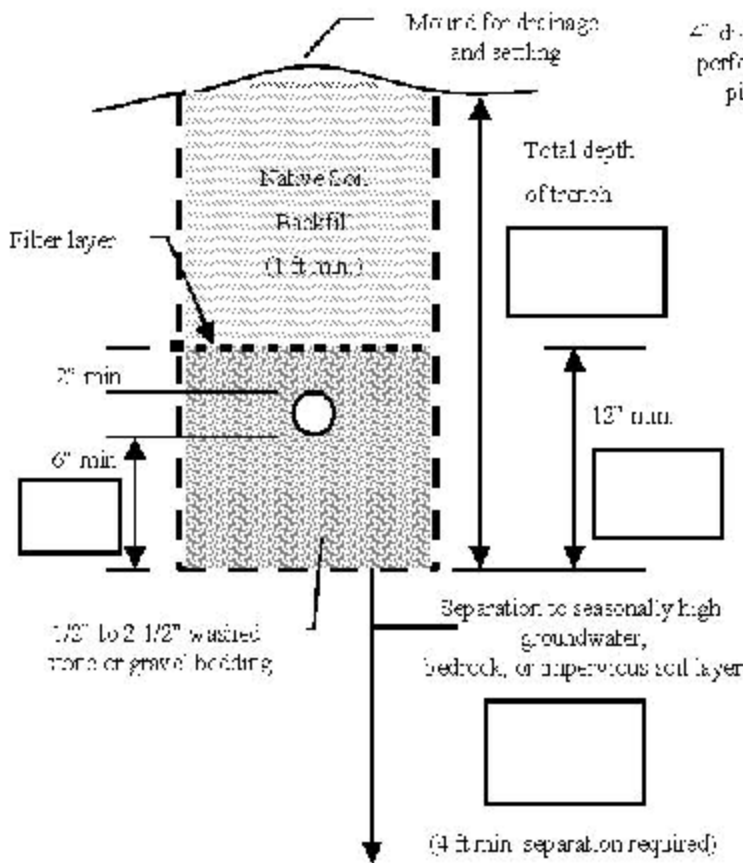

Four Trench Pipe Leachfield

CROSS SECTION

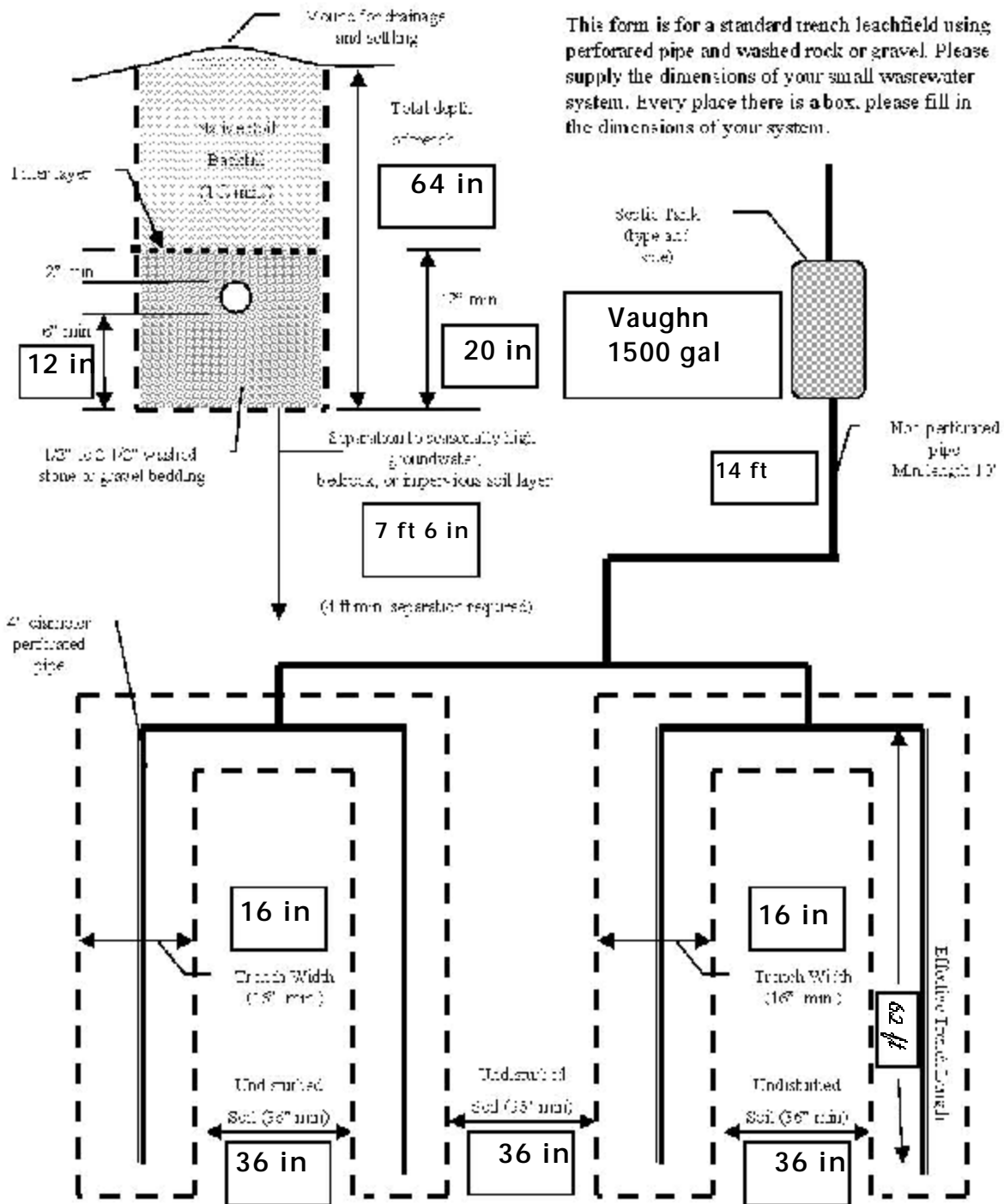

EXAMPLE

Four Trench Pipe Leachfield

CROSS SECTION

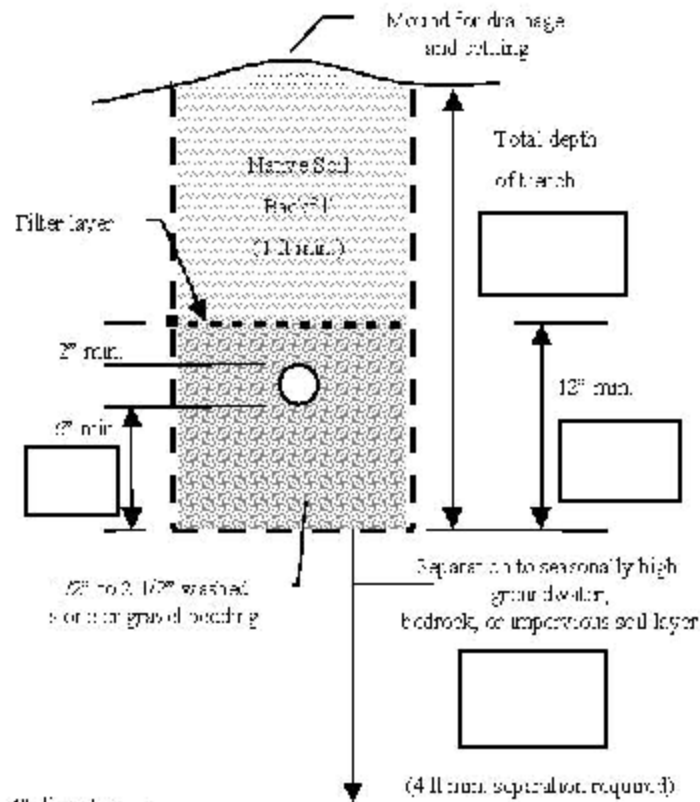

Four Equal Parallel Trenches

4 equal parallel Max. length = 75 ft

This form is for a standard trench leachfield using perforated pipe and washed rock or gravel. Please supply the dimensions of your small wastewater system. Every place there is a box, please fill in the dimensions of your system.

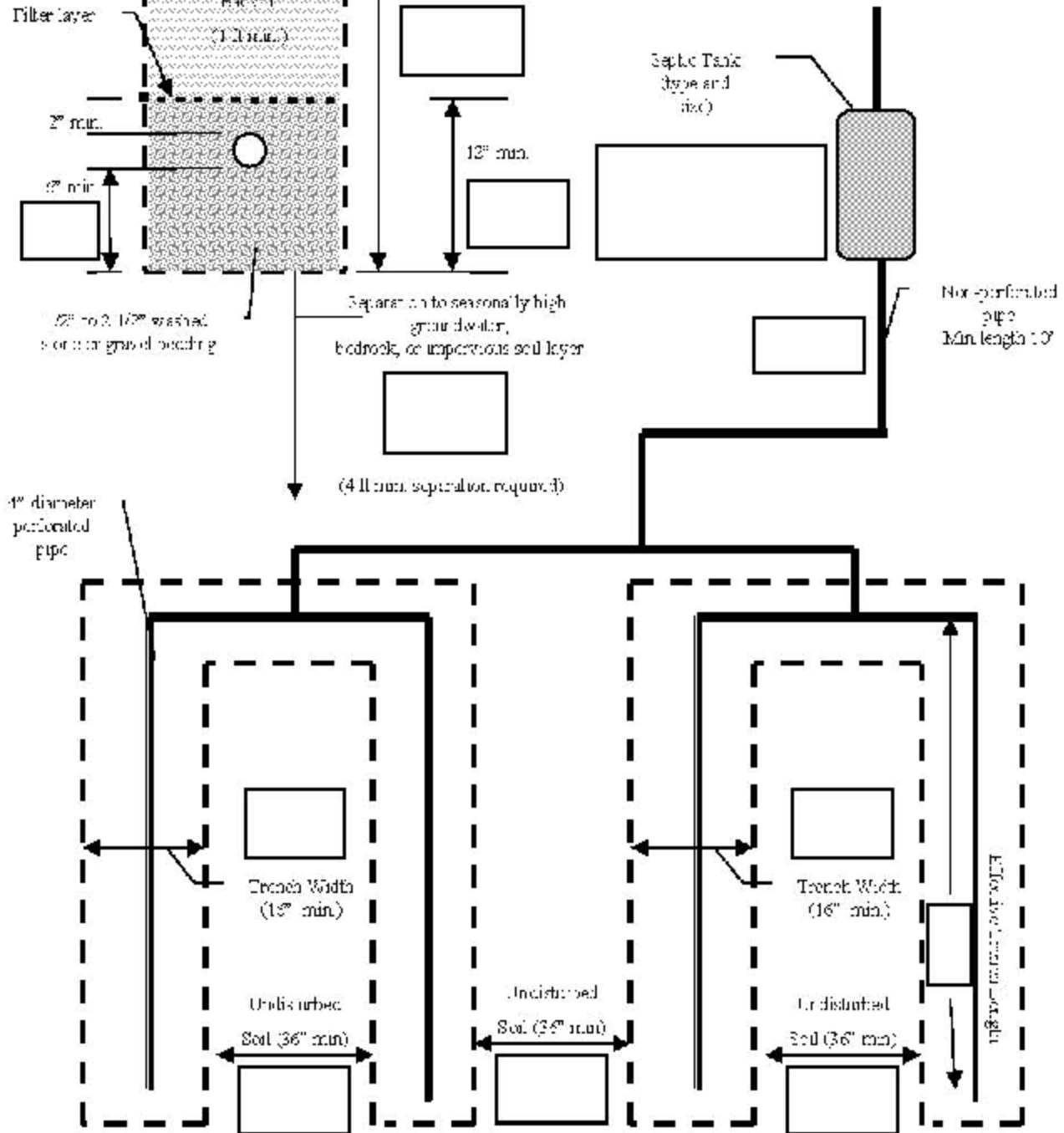

Multiple Trench Pipe Leachfield

Multiple Equal Trenches with Distribution Box

CROSS SECTION

This form is for a standard trench leachfield using perforated pipe and washed rock or gravel. Please supply the dimensions of your small wastewater system. Every place there is a box, please fill in the dimensions of your system.

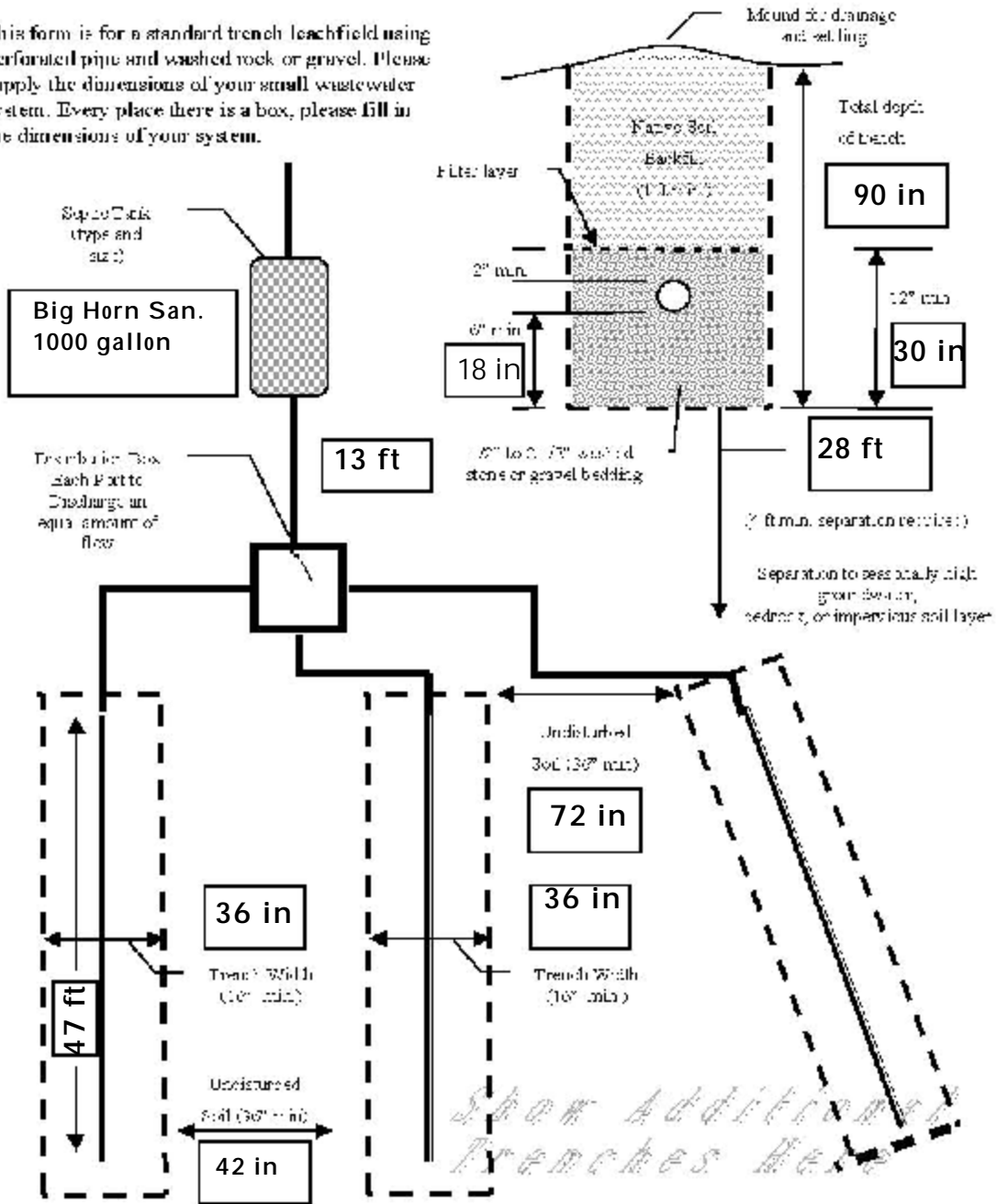

EXAMPLE

Multiple Trench Pipe Leachfield

Multiple Equal Trenches with Distribution Box

CROSS SECTION

This form is for a standard trench leachfield using perforated pipe and washed rock or gravel. Please supply the dimensions of your small wastewater system. Every place there is a box, please fill in the dimensions of your system.

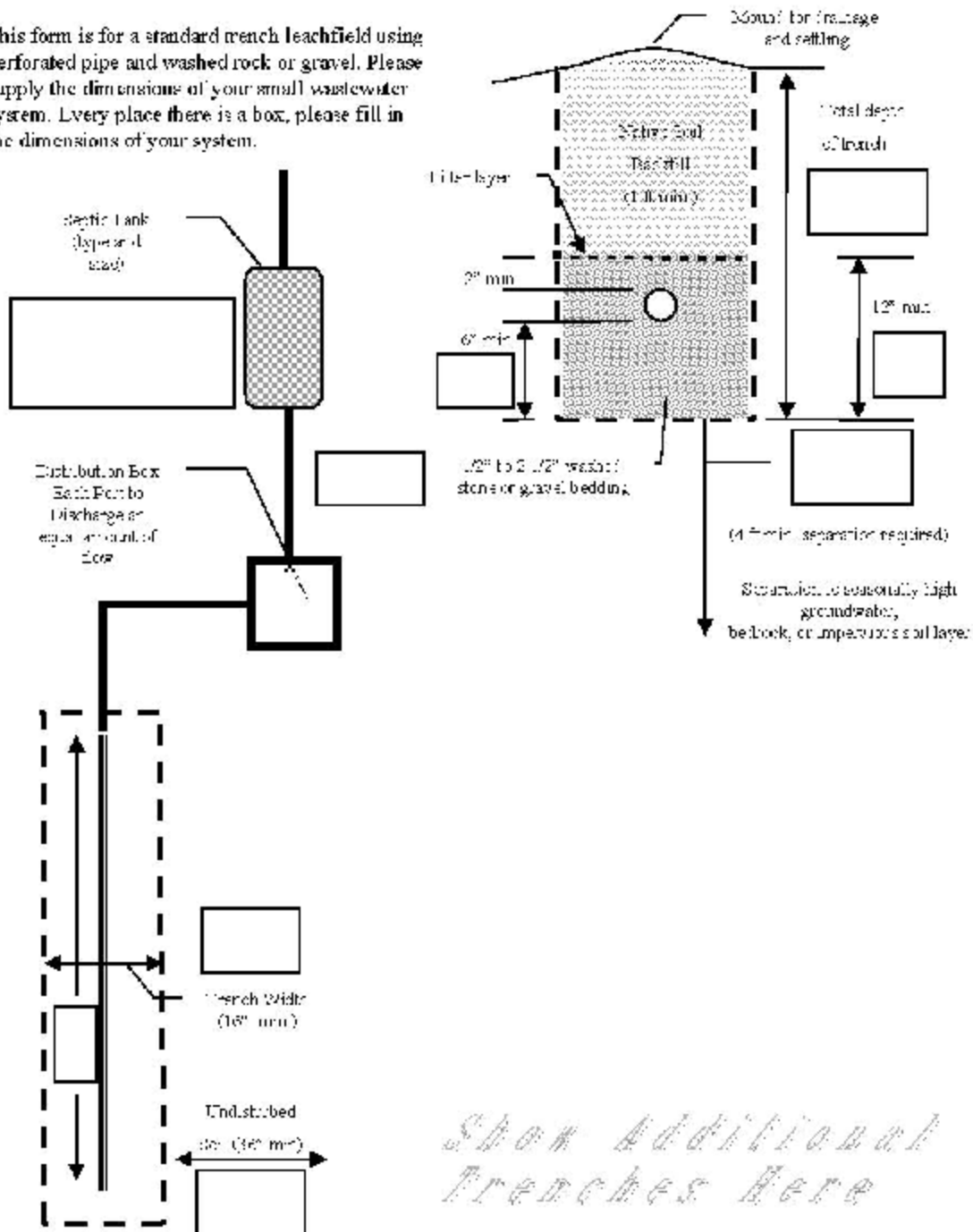

Bed Type Pipe Leachfield

Rectangular Bed

This worksheet is for a bed type leachfield using perforated pipe. Where boxes appear please supply the dimensions of your leachfield.

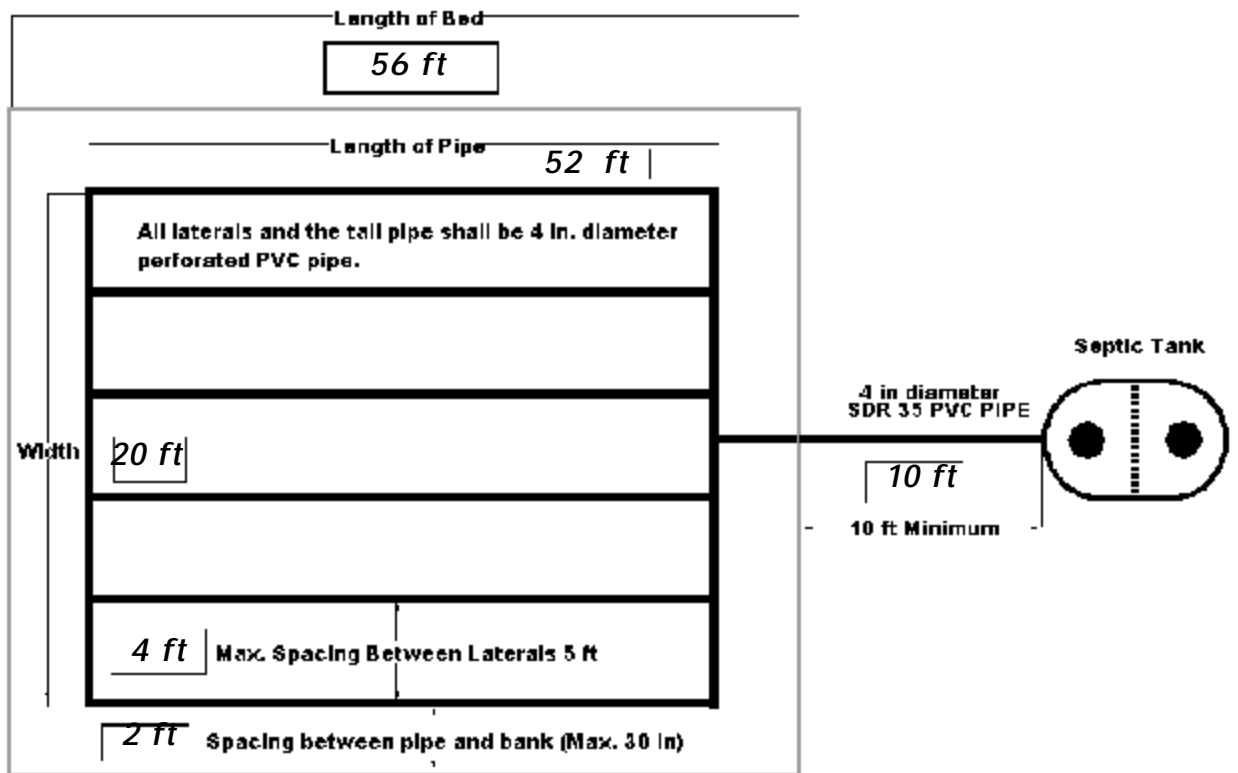
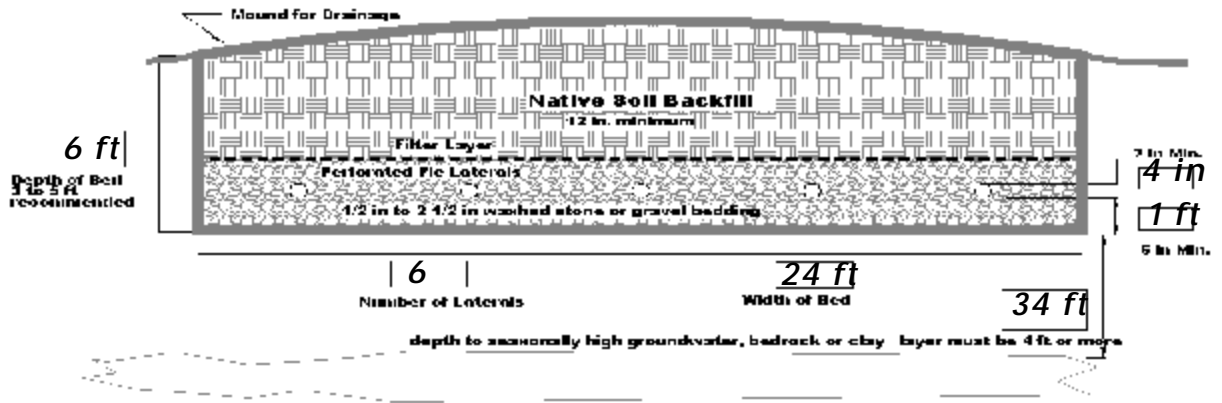

EXAMPLE

Bed Type Pipe Leachfield

Rectangular Bed

This worksheet is for a bed type leachfield using perforated pipe. Where boxes appear please supply the dimensions of your leachfield.

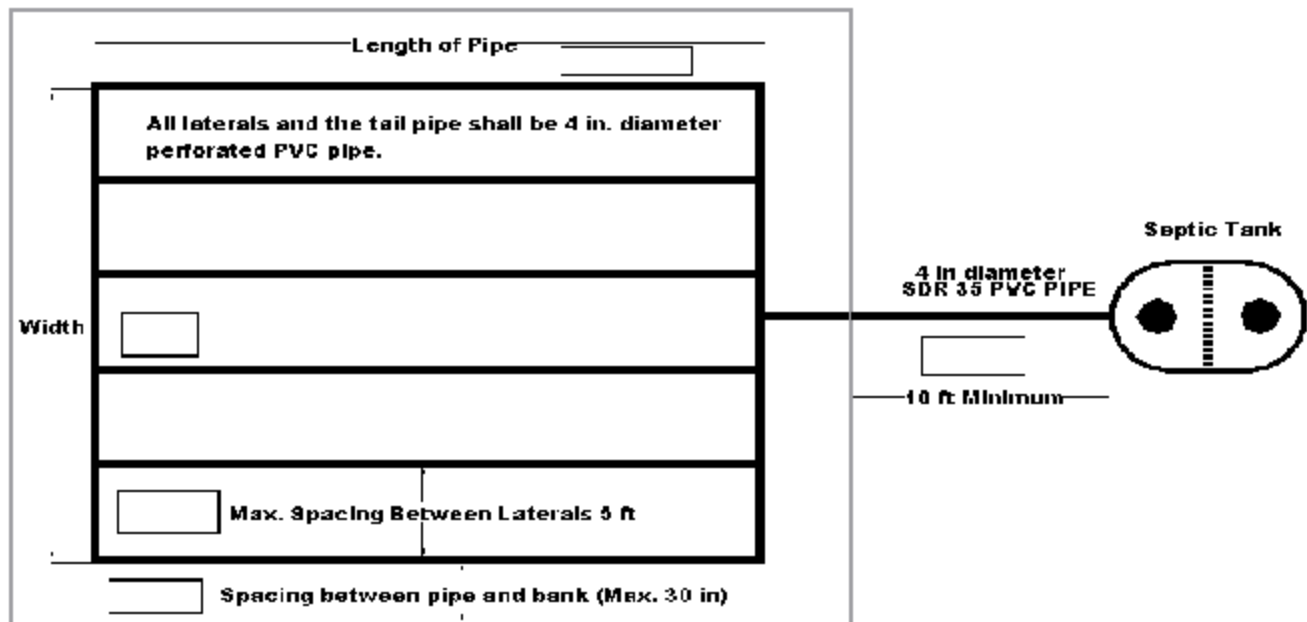
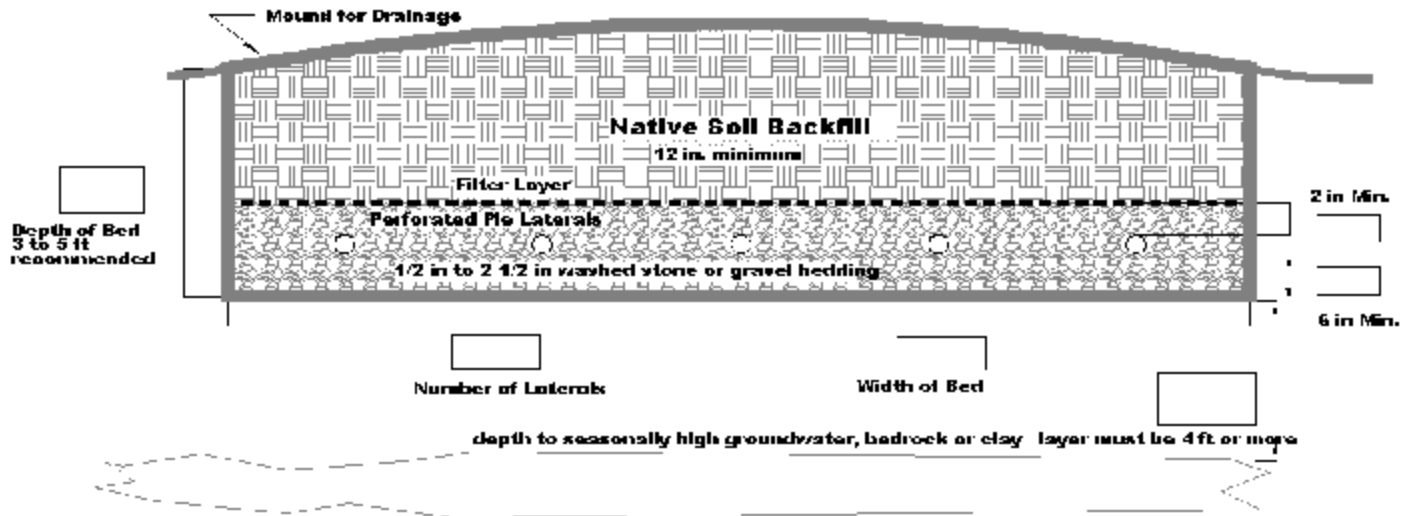

Single Trench Chambered Leachfield

This worksheet is for a trench type Leachfield using chamber units. Where boxes appear please supply the dimensions of your leachfield.

Type of Chamber:

Brand HANCOR

Model High Cap. Unit

Dimensions: Length 6.25 ft

Width 34 in Height 17.5 in

Number of Sections Req'd five

(From Section E.4)

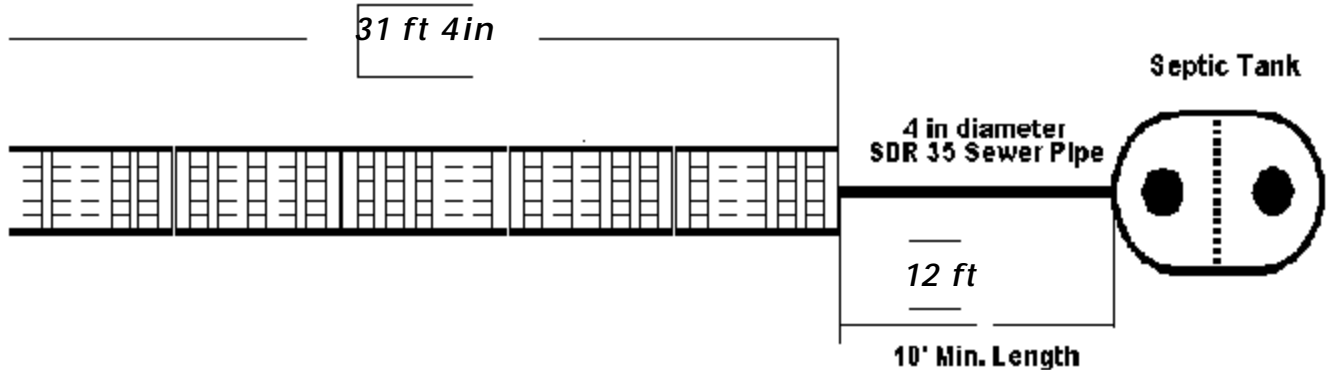
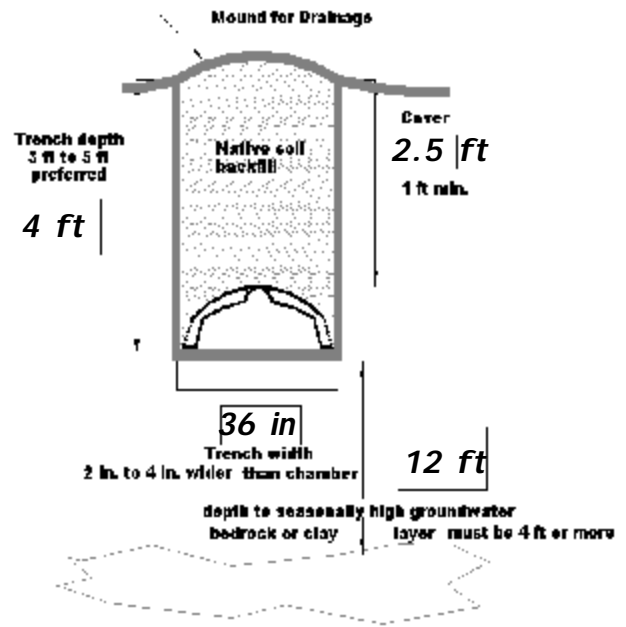

EXAMPLE

Single Trench Chambered Leachfield

This worksheet is for a trench type Leachfield using chamber units. Where boxes appear please supply the dimensions of your leachfield.

Type of Chamber:

Brand _____

Model _____

Dimensions: Length _____

Width _____ Height _____

Number of Sections Req'd _____

(From Section E.4)

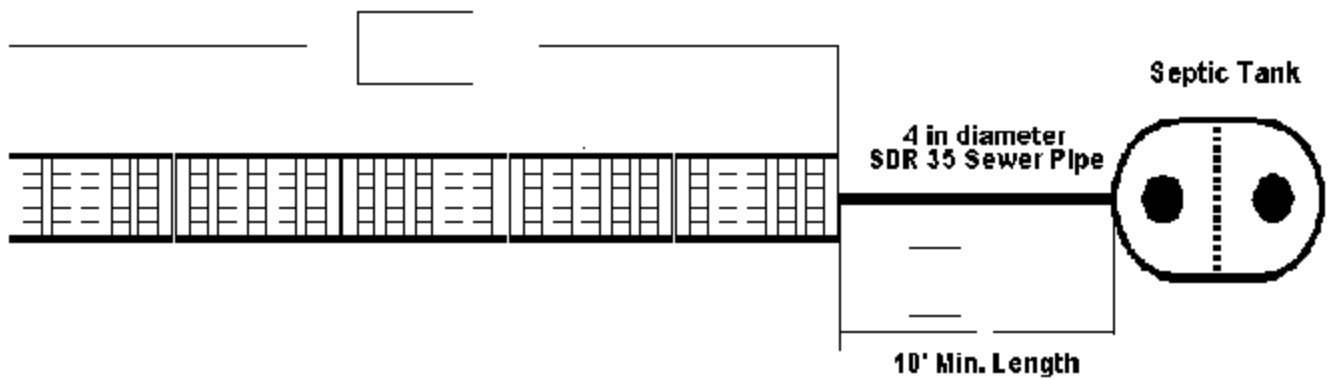
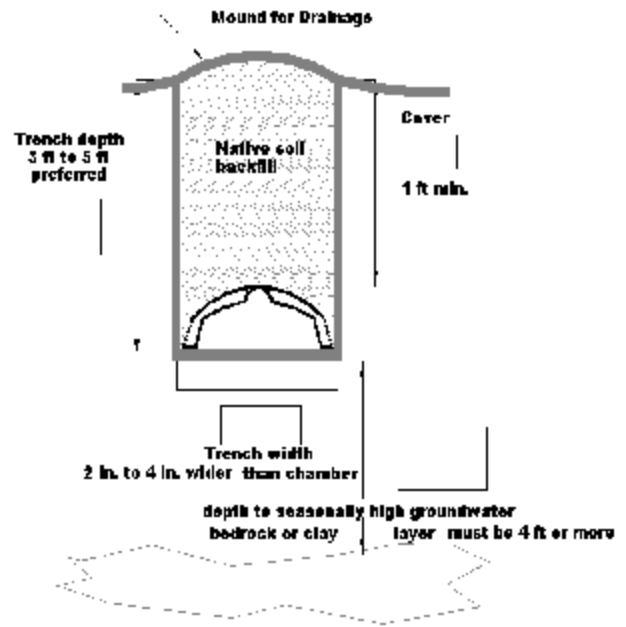

Two Trench Chambered Leachfield

This worksheet is for a trench type leachfield using chamber units. Where boxes appear please supply the dimensions of your leachfield.

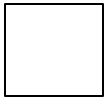

Type of Chamber:

Brand Infiltrator

Model Equalizer 36

Dimensions: Length 8.44 ft

Width 18 in Height 12 in

Number of Sections Req'd 14

(From Section E.4)

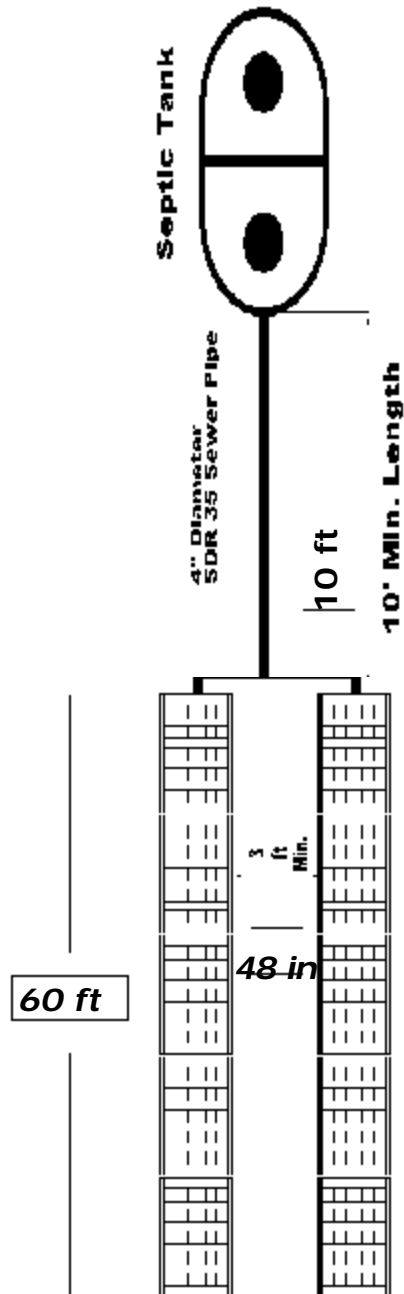
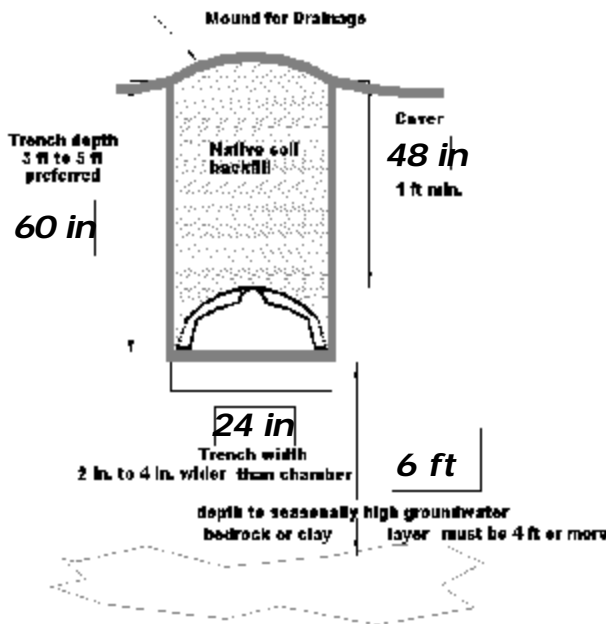

EXAMPLE

Two Trench Chambered Leachfield

This worksheet is for a trench type leachfield using chamber units. Where boxes appear please supply the dimensions of your leachfield.

Type of Chamber:

Brand _____

Model _____

Dimensions: Length _____

Width _____ Height _____

Number of Sections Req'd _____

(From Section E.4)

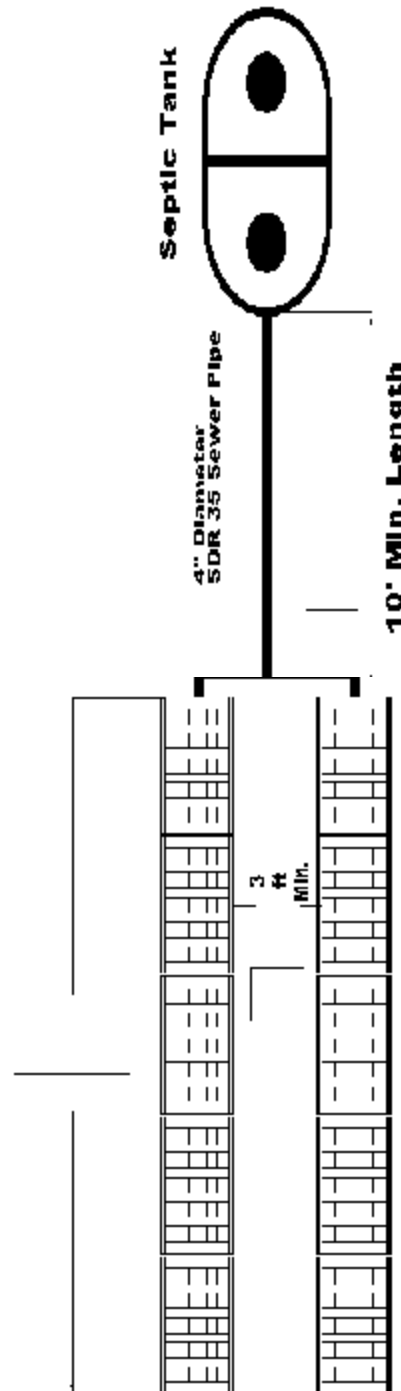
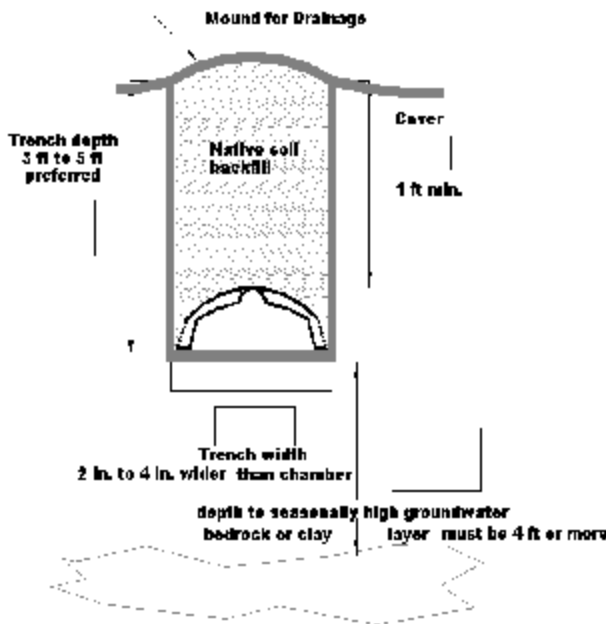

Four Trench Chambered Leachfield

Four Equal Length Trenches

This worksheet is for a trench type Leachfield using chamber units. Where boxes appear please supply the dimensions of your leachfield.

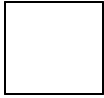

Type of Chamber:

Brand Biodiffuser

Model low Profile Unit

Dimensions: Length 6 ft 4 in

Width 34 in Height 11 in

Number of Sections Req'd 16
(From Section E.4)

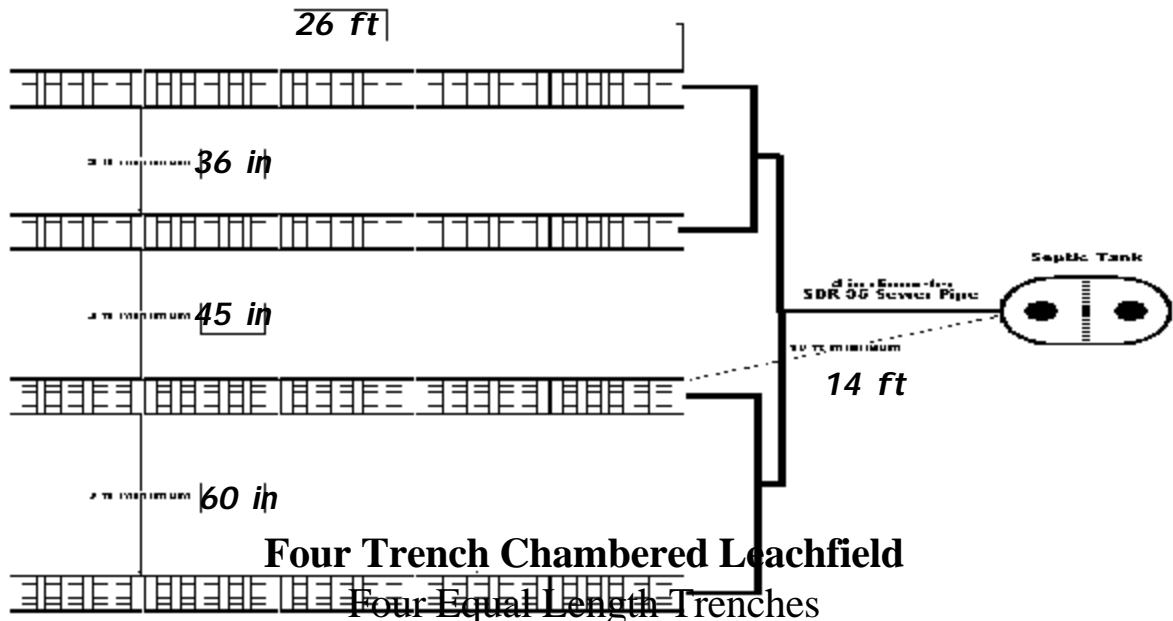
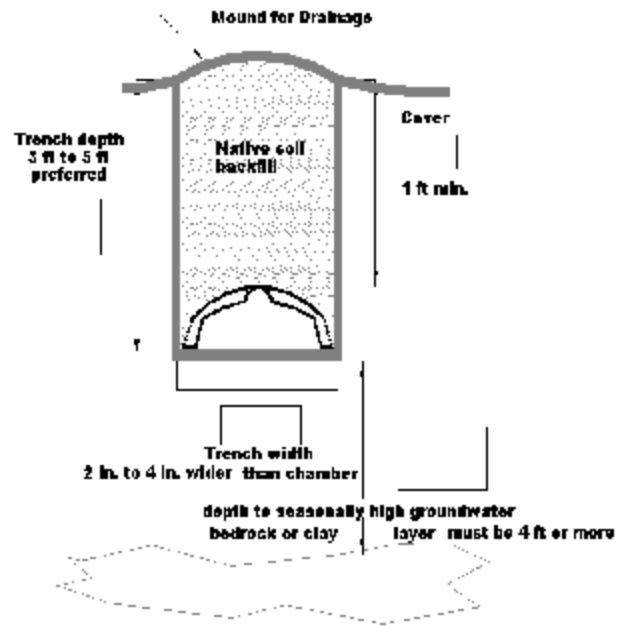

Four Trench Chambered Leachfield
Four Equal Length Trenches

EXAMPLE

Four Trench Chambered Leachfield

Four Equal Length Trenches

This worksheet is for a trench type Leachfield using chamber units. Where boxes appear please supply the dimensions of your leachfield.

Type of Chamber: _____

Brand _____

Model _____

Dimensions: Length _____

Width _____ Height _____

Number of Sections Req'd _____
(From Section E.4)

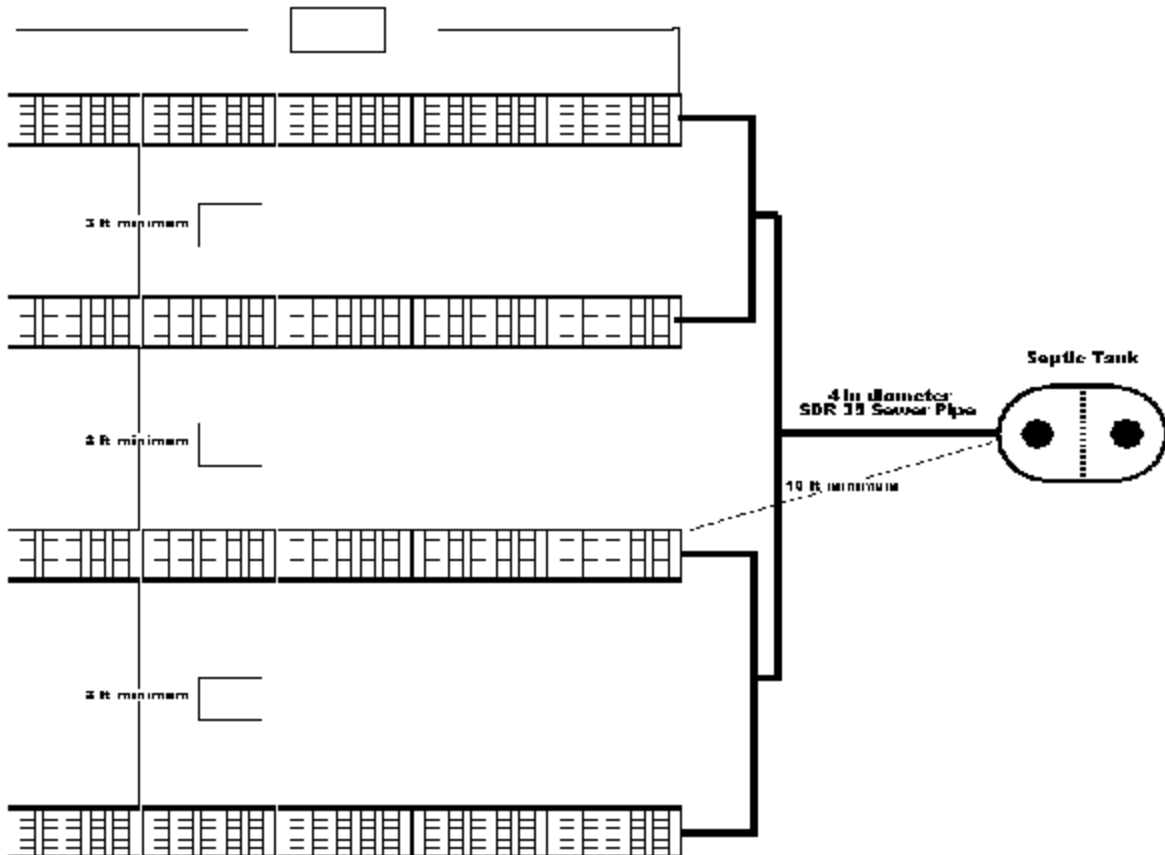
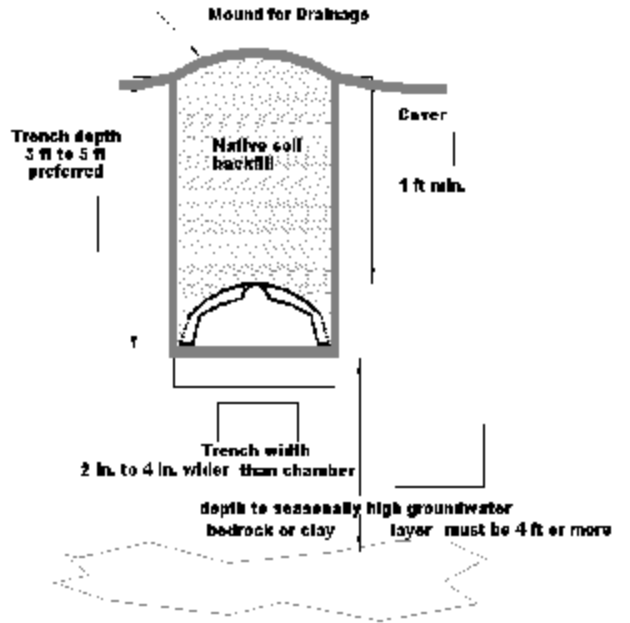

Multiple Trench Chambered Leachfield

Many Equal Length Trenches

This worksheet is for a trench type Leachfield using chamber units. Where boxes appear please supply the dimensions of your leachfield.



Type of Chamber:

Brand Infiltrator

Model Standard

Dimensions: Length 6ft 3 in

Width 34 in Height 12 in

Number of Sections Req'd 60

(From Section E.4)

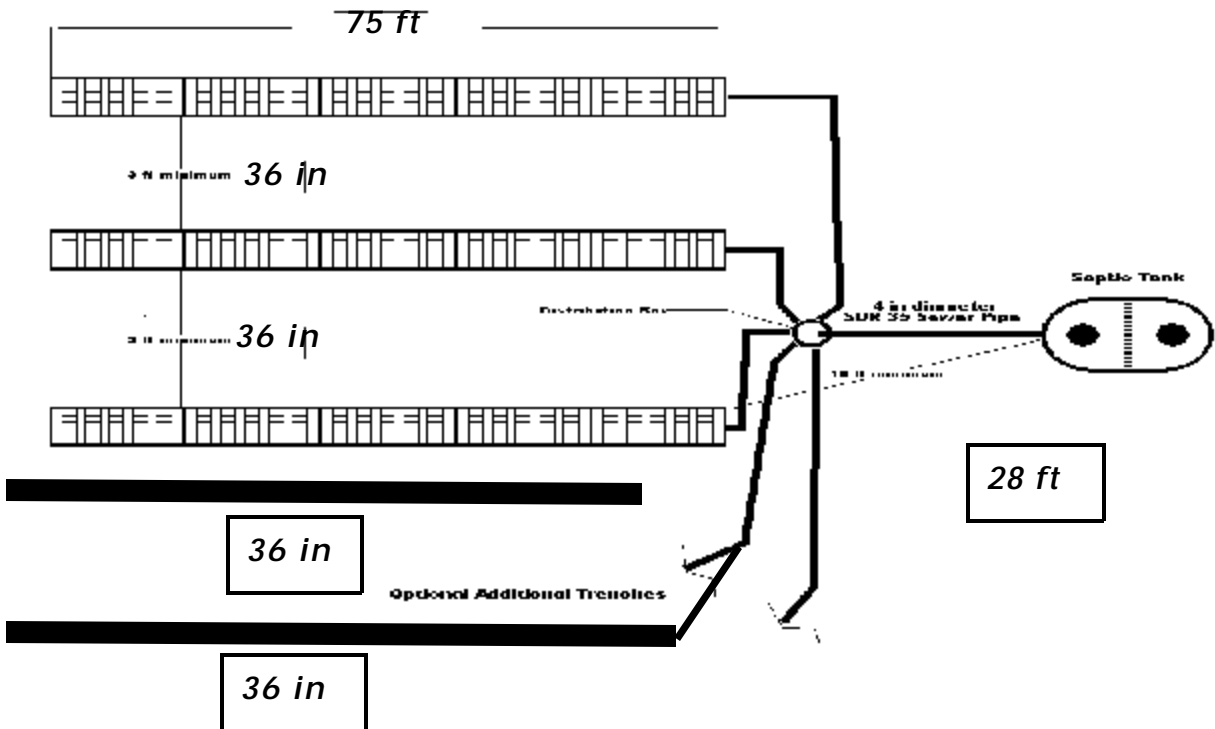
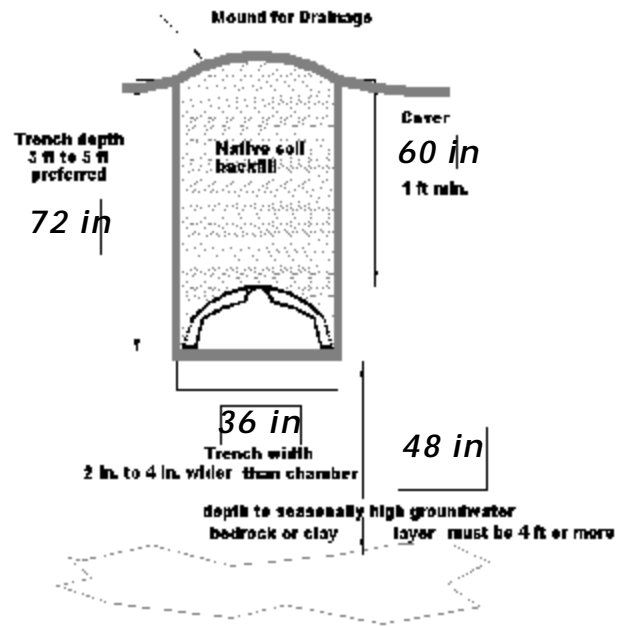

EXAMPLE

Multiple Trench Chambered Leachfield

Many Equal Length Trenches

This worksheet is for a trench type Leachfield using chamber units. Where boxes appear please supply the dimensions of your leachfield.

Type of Chamber: _____

Brand _____

Model _____

Dimensions: Length _____

Width _____ **Height** _____

Number of Sections Req'd _____

(From Section E.4)

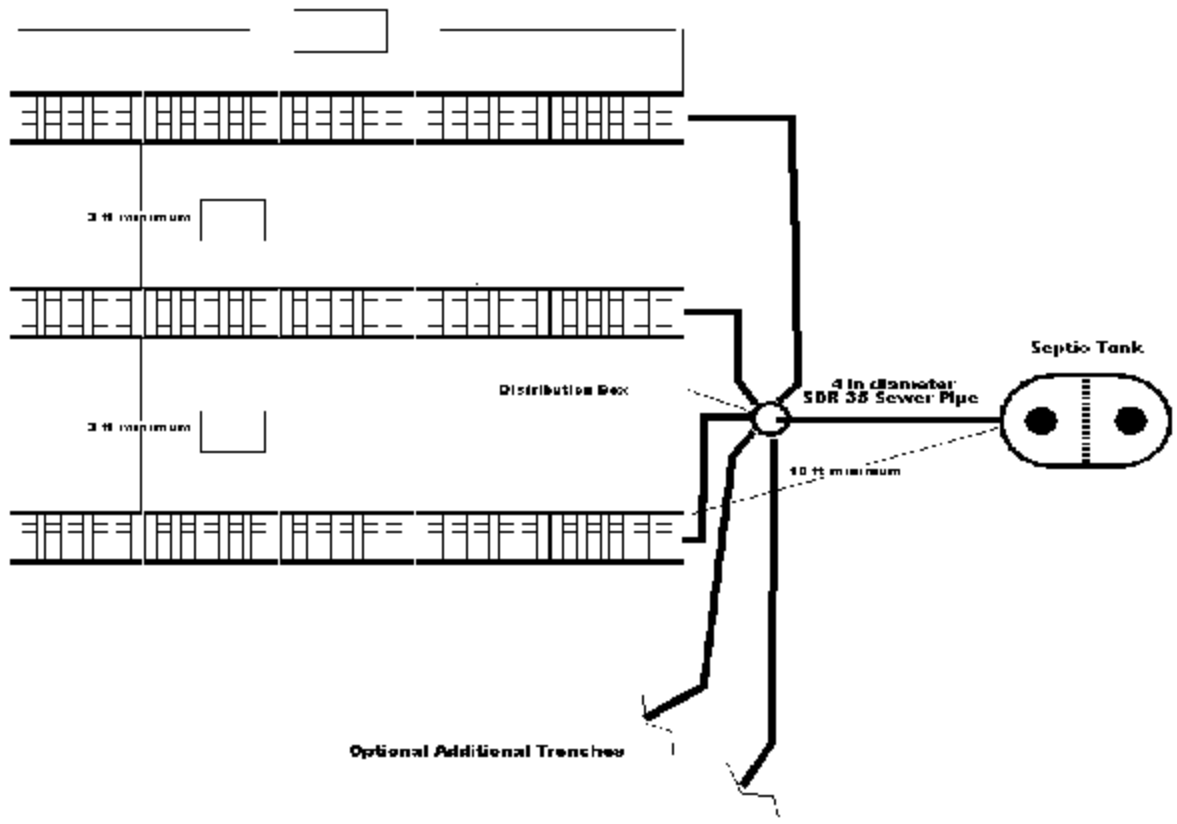
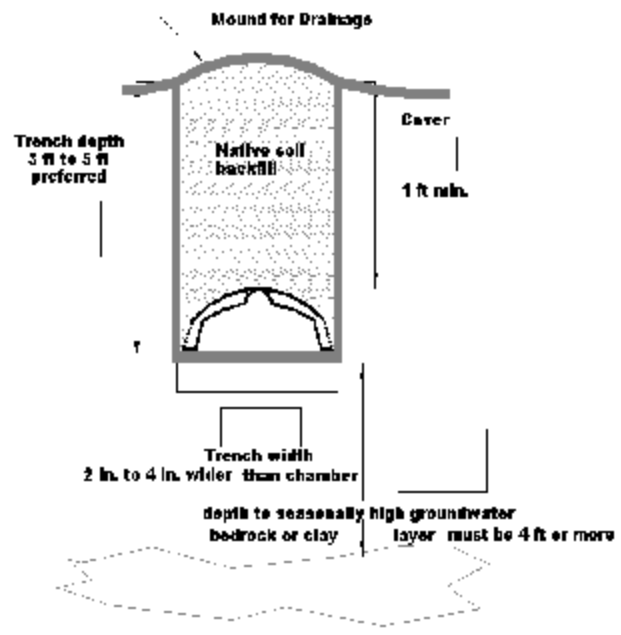

Bed Type Chambered Leachfield

Rectangular Bed

This worksheet is for a bed type leachfield using chamber units. Where boxes appear please supply the dimensions of your leachfield.

Type of Chamber: Brand HANCOR Model High Cap. Unit

Dimensions: Length 6.25 ft Width 34 in Height 17.5 in

Number of Sections Req'd 108

(From Section E.5)

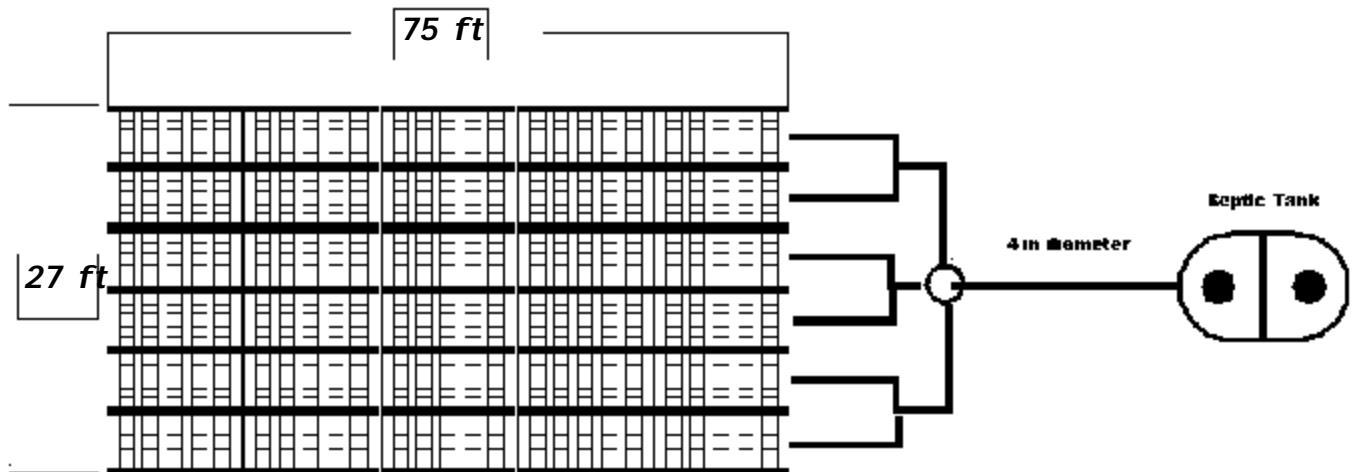
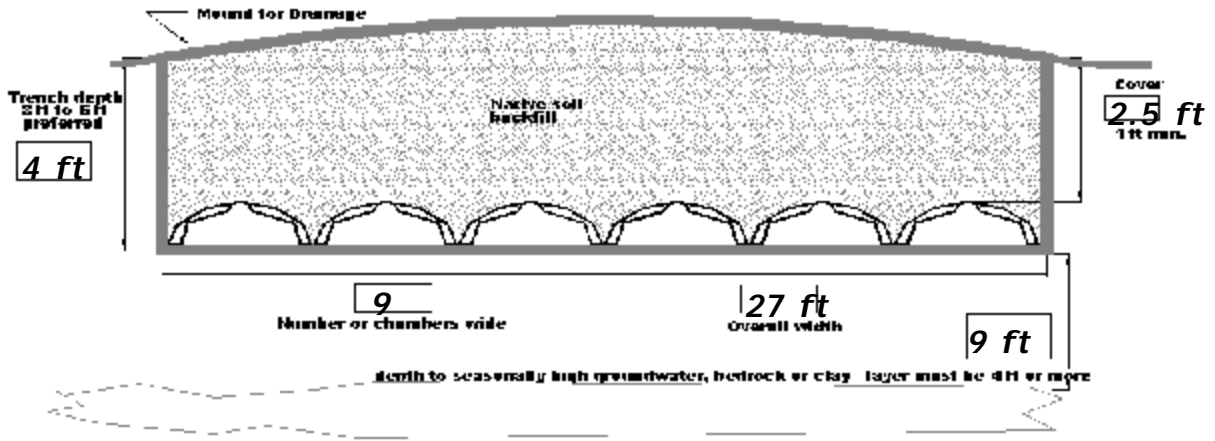

EXAMPLE

Bed Type Chambered Leachfield

Rectangular Bed

This worksheet is for a bed type leachfield using chamber units. Where boxes appear please supply the dimensions of your leachfield.

Type of Chamber: Brand _____ Model _____

Dimensions: Length _____ Width _____ Height _____

Number of Sections Req'd _____
 (From Section E.5)

